

DATA SHEET

SL-205XX series

Diamondback LED mini light bar

sentinel
vehicle lighting

R65

R10

Images



Dimensions

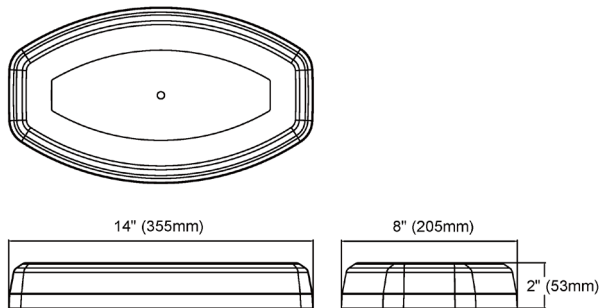

FP#	Flash Patterns		
1	Random	13	Quint (all)
2	Single (split)	14	Mega (all)
3	Double (split)	15	Ultra (all)
4	Quad (split)	16	Single-Quad (all)
5	Quint (split)	17	Single H/L (all)
6	Mega (split)	18	Steady (half)
7	Ultra (split)	19	Steady (all)
8	Single-Quad (split)	20	Single (2Hz)
9	Single H/L (split)	21	Double (2Hz)
10	Single (all)	22	Triple (2Hz)
11	Double (all)	23	Quad (2Hz)
12	Quad (all)		

Part numbers

SL-20501	Diamondback LED mini-bar, 2 bolt mount - amber
SL-20511	Diamondback LED mini-bar, vacuum magnetic mount - amber
SL-20599	Diamondback single bolt mounting kit

Specifications

Functions:	LED mini light bar
LEDs:	24 x high-intensity LEDs, amber
Hours of operation:	LEDs rated to 100,000 hours of operation
Lens colour:	Clear
Flash patterns:	23 selectable flash patterns Non-volatile memory recalls last flash pattern used at power up Multiple units can be synchronised
Certifications:	ECE R65 Class1 ECE R10-04 SAE J845 Class1
Dimensions:	355mm x 205mm
Voltage:	Dual voltage 12/24Vdc
Operating temperature:	-20°C to +50°C
Low power function:	Low power function available for night-time use
Vibration resistance:	Yes
Mounting:	2-bolt mount and vacuum-magnetic mount versions available
Wiring:	2-bolt mount: Red - Vcc: 30cm (18 AWG) Black - GND: 30cm (18 AWG) Blue - flash patterns & sync: 30cm (18 AWG) Vacuum-magnetic mount: Dual-button cigar plug: 300cm
Fuse:	8 AMP recommended
Power rating:	Average: 34.5 Watts (varies with flash pattern) Maximum: 69 Watts
Max current draw:	5.75A @ 12V / 2.88A @ 24V
Reverse polarity protection:	Yes
Warranty:	3 years

Materials

Lens:	Polycarbonate
Housing:	Polycarbonate & aluminium