

# DATA SHEET

## SL-1065X series

### LED directional pad warning light

sentinel  
vehicle lighting

R65

R10

#### Images



#### Dimensions

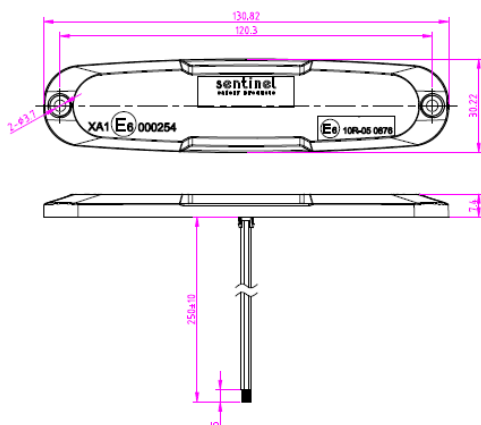

#### Part numbers

SL-10651	LED directional pad, amber
SL-10652	LED directional pad, red
SL-10653	LED directional pad, blue
SL-10654	LED directional pad, white

#### Specifications

<b>Functions:</b>	LED directional pad warning light Super low-profile: 7.4mm deep
<b>LEDs:</b>	6 x high-power LEDs
<b>Lens colour:</b>	Clear
<b>Flash pattern:</b>	21 selectable flash patterns, including steady burn Multiple units can be synchronised to flash simultaneously or alternately
<b>Certifications:</b>	ECE Reg 10: E6-10R-050876 ECE Reg 65: E6-65R-000254 (amber) E6-65R-000255 (red) E6-65R-000256 (blue)
<b>Dimensions:</b>	7.4mm deep
<b>Voltage:</b>	Multivoltage
<b>Operating range:</b>	9-32Vdc
<b>IP rating:</b>	IP67
<b>Operating temperature:</b>	-30°C to +65°C
<b>Mounting:</b>	Self-adhesive pad mount or screw mount
<b>Wiring:</b>	20cm long insulated wires 24AWG White = power Black = ground Brown = synchronisation & flash patterns
<b>Power rating:</b>	SL-10451: 12.5W @ 12V / 11.9W @ 24V SL-10452: 8.4W @ 12V / 8.7W @ 24V SL-10453: 14.1W @ 12V / 16.4W @ 24V SL-10454: 3.8W @ 12V / 3.8W @ 24V
<b>Reverse polarity protection:</b>	Yes
<b>Warranty:</b>	3 years

#### Materials

<b>Lens:</b>	Polycarbonate
<b>Base:</b>	Aluminium