

# DATA SHEET

SL-1047X series

LED directional warning light

sentinel  
vehicle lighting

R65

R10

## Images



## Dimensions

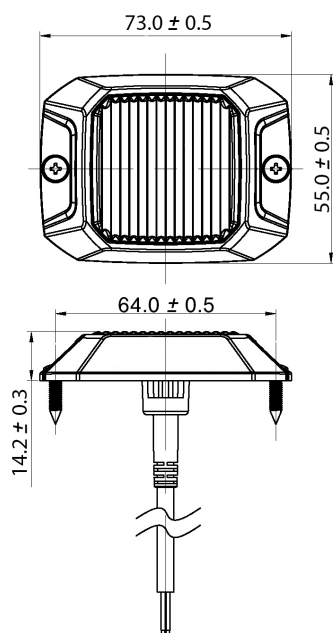

## Specifications

<b>Functions:</b>	LED directional warning light
<b>LEDs:</b>	4 x high power LEDs
<b>Flash patterns &amp; synchronisation:</b>	Multiple selectable flash patterns Multiple units can be synchronised
<b>Certifications:</b>	ECE Reg 10-05 16505 ECE Reg 65: XA100 6401 (amber only)
<b>Dimensions:</b>	73 x 55 x 14mm
<b>Voltage:</b>	Dual voltage 12/24V
<b>IP rating:</b>	IP69K
<b>Operating temperature:</b>	-30°C to +50°C
<b>Mounting:</b>	Surface mount
<b>Wiring:</b>	Red = power Black = ground Green = flash pattern selection & synchronising White = alternate flash
<b>Power rating:</b>	10W
<b>Current draw:</b>	Amber: 0.75A @ 13.5Vdc / 0.38A @ 28Vdc Red: 0.64A @ 13.5Vdc / 0.35A @ 28Vdc Blue: 0.76A @ 13.5Vdc / 0.40A @ 28Vdc
<b>Reverse polarity protection:</b>	Yes
<b>Warranty:</b>	3 years

## Materials

<b>Lens:</b>	Polycarbonate
<b>Housing:</b>	Aluminium die cast

## Part numbers

SL-10471	Surface mount LED directional warning light, R65 - amber
SL-10472	Surface mount LED directional warning light - red
SL-10473	Surface mount LED directional warning light - blue