

DATA SHEET

SL-1043X series

LED directional warning light

sentinel
vehicle lighting

R65

R10

Images



Optional mounting accessories



Dimensions

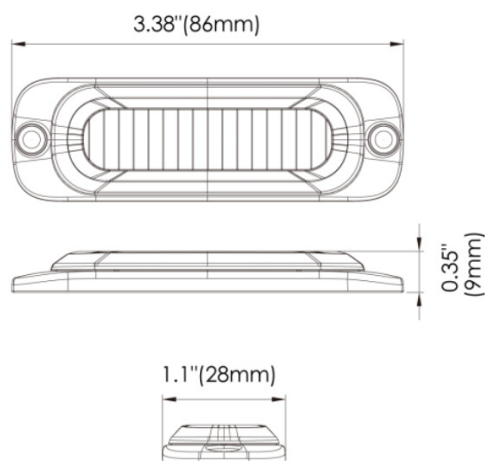

Specifications

Functions:	LED directional warning light - R65 Super-low profile design - only 9mm deep
LEDs:	3 x high-power diodes - amber
Lens colour:	Clear
Flash patterns:	16 selectable flash patterns, including steady-burn
Synchronisation:	Up to 15 units can be synchronised to flash simultaneously or alternately
Certifications:	ECE R65: E6 65R XA1 000228 (amber) ECE R10: E6 10R 05 0823
Dimensions:	86 x 27 x 9mm
Voltage:	Multi-voltage 9-32Vdc
IP rating:	IP68
Operating temperature:	-30°C to +65°C
Mounting:	Screw mount Optional bezels or L-shaped bracket available
Wiring:	26.5cm long insulated wires 20AWG with partially stripped ends Red = power Black = ground Yellow = synchronisation & flash patterns
Average power:	3.55 Watts (varies by flash pattern)
Maximum power:	7.1 Watts
Average current draw:	0.30A @ 12Vdc / 0.15A @ 24Vdc (varies by flash pattern)
Maximum current draw:	0.59A @ 12Vdc / 0.30A @ 24Vdc
Reverse polarity protection:	Yes
Warranty:	5 years

Part numbers

SL-10431	LED directional - amber
SL-10436	Black bezel
SL-10437	Chrome bezel
SL-10438	White bezel
SL-10439	Mounting bracket - L shaped

Materials

Lens:	Polycarbonate
Base:	Aluminium